

Becherwerk Bucket elevator Élévateur à godets

Maßänderungen vorbehalten The right to alterations in dimensions is reserved Sous réserve de modification des côtes
Sonderabmessungen auf Anfrage Special dimensions on request Dimensions spéciales sur demande

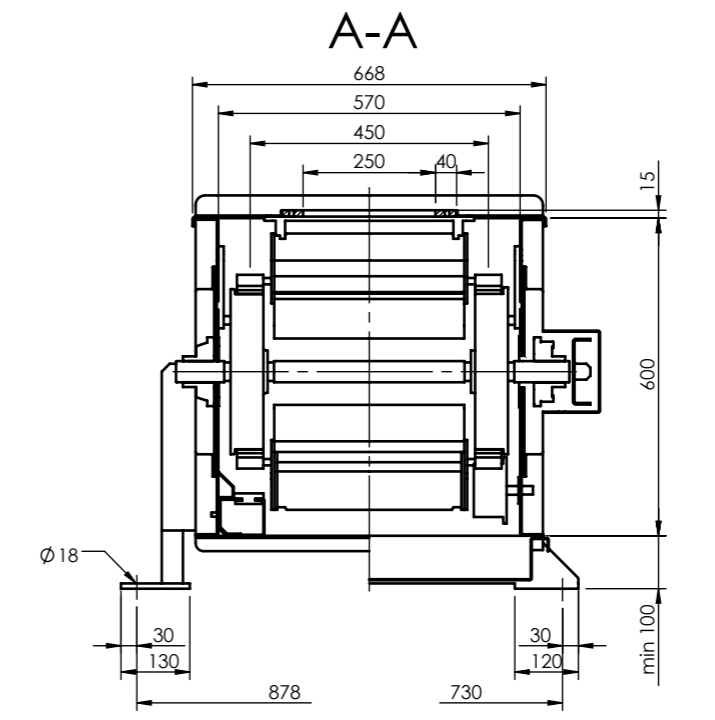

gleitend	mit Tragrollen
sliding support	rolling support
supportage glissant	supportage par galets
Becherrücklauf / return of buckets / retour du godets	

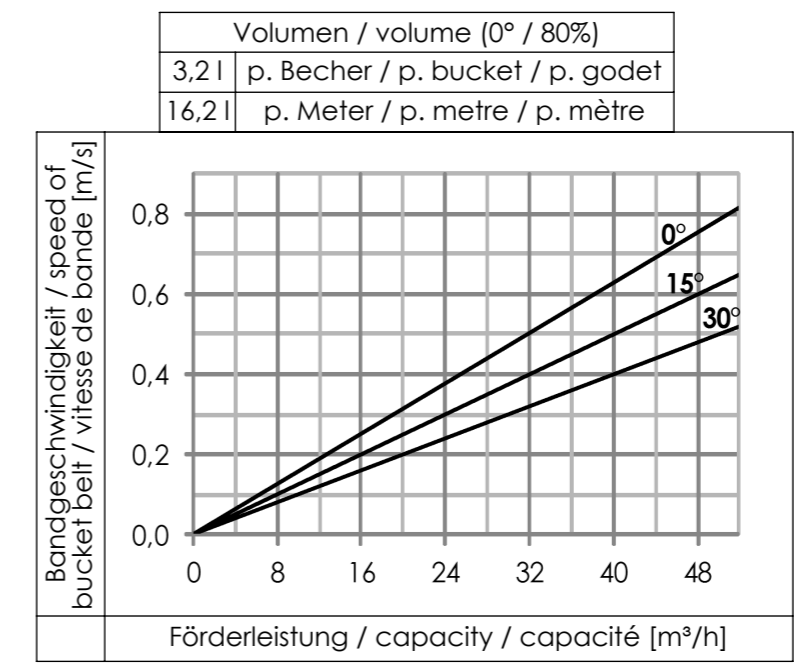

CC Fuß / bottom / pied	min 1410
CC vertikal / vertical	min 1600
Gewicht / weight / poids	ca. / env. 1450kg
Gewicht / weight / poids	
vertikal / vertical	ca. / env. 105kg/m
horizontal	ca. / env. 140kg/m
- mehrere Aufgabestellen möglich - Aufgabelängen variabel	
- additional feed openings are available - length of feed slot variable	
- plusieurs entrées produit possible - longueur bride d'entrée sur demande	

Förderleistung Füllungsgrad 80%	
0°	freifließendes Produkt
15°	pulverförmiges Produkt
30°	körniges Produkt
Conveying capacities Filling level 80%	
0°	free flowing product
15°	powdered product
30°	granular product
Capacités de transport Taux de remplissage 80%	
0°	produit s'écoulant librement
15°	produit pulvérulent
30°	produit granuleux

Material		Maßstab/Scale		Gewicht/Weight	
Datum/Date		Name/Name		Benennung / Description	
3D Bearb./Changed	11.06.18	Rös	Maßblatt dimension sheet WB370 C A407		
3D Geprüft/Reviewed	24.06.19	AK			
2D Bearb./Changed	11.06.18	Rös			
2D Geprüft/Reviewed	24.06.19	AK			
Zngs.-Nr./Drawing-No		Zng.-Index		Blatt/Sheet	
20-1029-00		-		1	
Ersatz für/ Substitute for		Ersetzt durch/ Replaced by		Blätter/ Sheets	
				1	
Rev.	Änderung/Change	Datum/Date	Ursprung/Origin	Freigegeben	
			20-1028-00		